



**RITTAL X PRESS**



HMI ENCLOSURES DELIVERED TO YOUR SPECIFICATION.

**NO ASSEMBLY REQUIRED.**

CUSTOMIZED ENCLOSURES RIGHT TO YOUR DOORSTEP

RELIABLE. FLEXIBLE. FAST.



GET THE INDUSTRY'S LEADING HMI ENCLOSURES, BUILT TO YOUR SPECIFICATIONS IN AS LITTLE AS 2 WEEKS

Here are two new programs that put you in control. Rittal lets you choose the most popular components of our VIP and Optipanel HMI enclosure systems. Then we ship them to you in just 2 weeks from receipt of your purchase order. If you require more customization, such as non-standard sizes and accessories, or even your own front panel design, we can handle that too. We'll ship your completed, customized system in just 4 weeks.

#### 2 Week Program

Simply choose the part number of the VIP or Optipanel from the selection charts. You can also indicate which standard pushbutton cutouts you require. That's it. Within just 2 weeks of receipt of your PO, your complete system is on its way.

#### 4 Week Program

This option lets you choose the VIP or Optipanel components that fit your requirements from any of those listed in the appropriate selection charts. This means you can select from a broader range of enclosure dimensions and accessories for even greater flexibility. Plus, with this option you can submit your own front panel design.



TRIM COLORS TO ORDER COVER TRIM, END TRIM AND SPACER TRIM ARE AVAILABLE IN FIVE COLORS. THE ENCLOSURE CORNER PROTECTORS ARE LIKEWISE PRODUCED IN THE CHOSEN TRIM COLOR. CUSTOMIZED COLORS CAN ALSO BE PRODUCED FOR LARGER ORDERS.

No one knows more about HMI cabinets than Rittal. As the world's leading enclosure manufacturer with over 13,000 products, Rittal combines pleasing aesthetics with carefully crafted functionality and exceptional value. Whether you need OptiPanel or VIP cabinets, Rittal has the resources to get them to you in record time.

# WHICH SYSTEM IS RIGHT FOR YOU?

## OPTIPANEL

The ideal combination of form, function and economy for smaller panels, Optipanel has a slender, sleek, flat design. The standard enclosure fits many commonly used front panels, and the system can be customized to your exact requirements.



- Standard version provides 3.9" installation depth for typical front panels 7U H x 19" (482.5 mm) W
- Other available installation depths: 1.97" (50 mm), 3.97" (100 mm), and 5.90" (150 mm)
- Can be configured to your precise requirements with housing, mullion, rear wall and keyboard housing
- Operator housing can be subdivided to accept multiple panels
- Pendant arm supports available
- UL/cUL Type 12/IP 55  
UL File Number: E76083

## VIP

Rittal's VIP operator interface system is the industry's premier HMI enclosure solution. No other system provides this range of sizes, accessories and customization. With VIP you can integrate your own control panel into an ergonomically designed enclosure precisely crafted for your application. VIP offers the option of a keyboard tray or housing, and an extensive list of accessories including pendant arm supports. Key system features include:



- Wide, narrow and combination frames to precisely match your application
- Installation depths from 6.10" (155 mm) through 17.28" (438 mm) for greater flexibility
- Keyboard housings that easily connect to the operator housing
- Available with or without heat dissipating cooling fins
- Operator housing can be subdivided to accept multiple panels
- UL/cUL Type 12/IP 55  
UL File Number: E76083

## RITTALXPRESS 2-WEEK OPTIPANEL PROGRAM

Rittal Xpress offers a comprehensive selection of enclosures and fully-assembled HMI enclosures in just two weeks from receipt of your order. Use the product selection guides on the following pages to create the code for your ideal HMI enclosure. A fax order form for enclosures with two-week availability is located on the next page of this brochure.

### OPTIPANEL — CODE BOX 1 — SELECT YOUR HMI ENCLOSURE SIZE

Code	Part No.	Description
<b>A</b>	9970859	Optipanel, 7U H x 19" (482.5 mm) W x 6" (150 mm) D Without Connection
<b>B</b>	9970860	Optipanel 7U H x 19" (482.5 mm) W x 6" (150 mm) D With Top Connection
<b>C</b>	9970861	Optipanel 7U H x 19" (482.5 mm) W x 6" (150 mm) D With Bottom Connection
<b>D</b>	9970862	Optipanel 7U H x 19" (482.5 mm) W x 6" (150 mm) D With Top & Bottom Connection
<b>E</b>	9970863	Optipanel 10.5U H x 19" (482.5 mm) W x 6" (150 mm) D Without Connection
<b>F</b>	9970864	Optipanel 10.5U H x 19" (482.5 mm) W x 6" (150 mm) D With Top Connection
<b>G</b>	9970865	Optipanel 10.5U H x 19" (482.5 mm) W x 6" (150 mm) D With Bottom Connection
<b>H</b>	9970866	Optipanel 10.5U H x 19" (482.5 mm) W x 6" (150 mm) D With Top & Bottom Connection



Without connection



Connection at top



Connection at bottom



Connection top and bottom

### OPTIPANEL — CODE BOX 2 — SELECT KEYBOARD OPTIONS

Code	Part No.	Description
<b>Y or N</b>	9970867	Code Y or N: Keyboard for Optipanel, Preconfigured with Panel, 3.5U H x 19" (482.5 mm) W x 4" (100 mm) D

Y = Yes keyboard is wanted  
N = No do not need



# RITTAL XPRESS 2-WEEK OPTIPANEL FORM

Configuring HMI enclosures has never been easier. Log onto [www.rittal.ca/rittalxpress/](http://www.rittal.ca/rittalxpress/) and complete our real-time configurator. Or fill out the simple form below and fax it to 1-800-399-0748.

Your Company \_\_\_\_\_ Your Phone \_\_\_\_\_

Your Name \_\_\_\_\_ Your Zip \_\_\_\_\_

Your E-mail \_\_\_\_\_ Your Account Number (if applicable) \_\_\_\_\_

Select your Optipanel enclosure size from options **A-H** on the opposite page and write the appropriate letter in the code box labeled **1**. Select your keyboard option (**Y = Yes** keyboard is wanted, or **N = No** keyboard is required). Please write your selection in the code box labeled **2**. Tell us about your cutouts. Please write the dimension for the cutout in the space provided. Please indicate the holes that you would like to activate by writing an A in each hole that will be 22.5 mm and B in each hole that will be 30.5 mm.

## BUILD YOUR ENCLOSURE CODE

0	2	1	2
---	---	---	---

### OPTIPANEL — FINAL STEP — PANEL CUT OUT SIZE AND PUSHBUTTONS REQUIRED

**7U with Pushbuttons**— Please write the height and the width of the panel cutout in the space provided below. Indicate the holes that you would like to activate by writing an A in each hole that will be 22.5 mm and B in each hole that will be 30.5 mm.

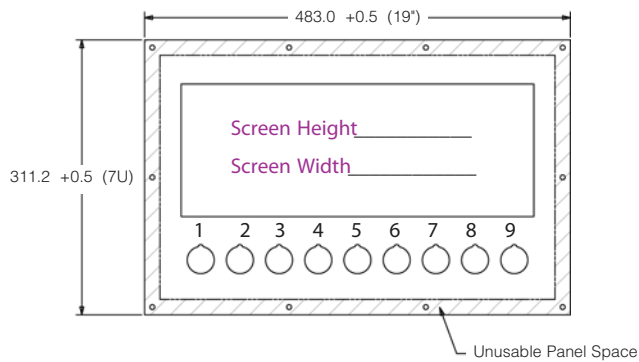

**7U** — Please write the height and the width of the panel cutout in the space provided below.

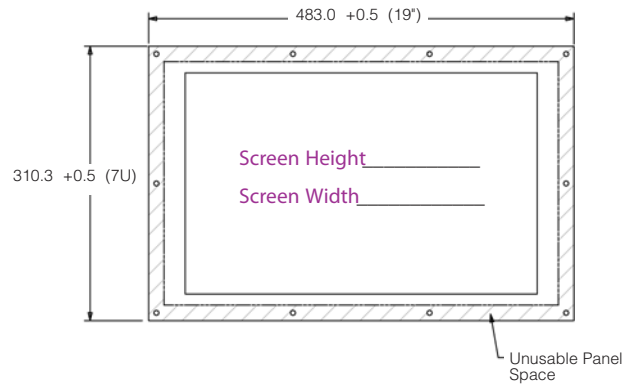

**10.5U with Pushbuttons**— Please write the height and the width of the panel cutout in the space provided below. Indicate the holes that you would like to activate by writing an A in each hole that will be 22.5 mm and B in each hole that will be 30.5 mm.

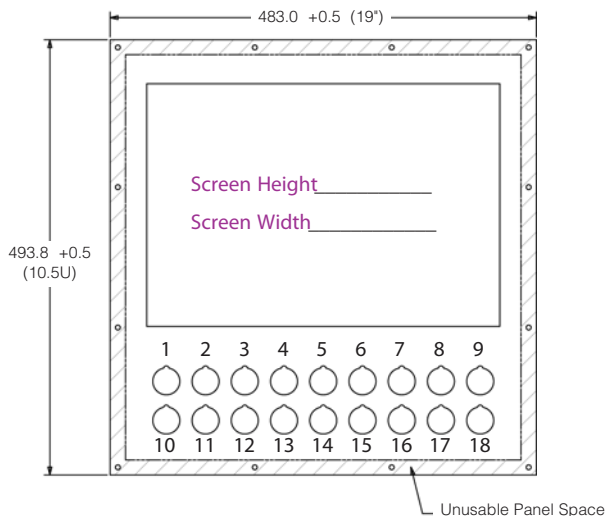

**10.5U** — Please write the height and the width of the panel cutout in the space provided below.

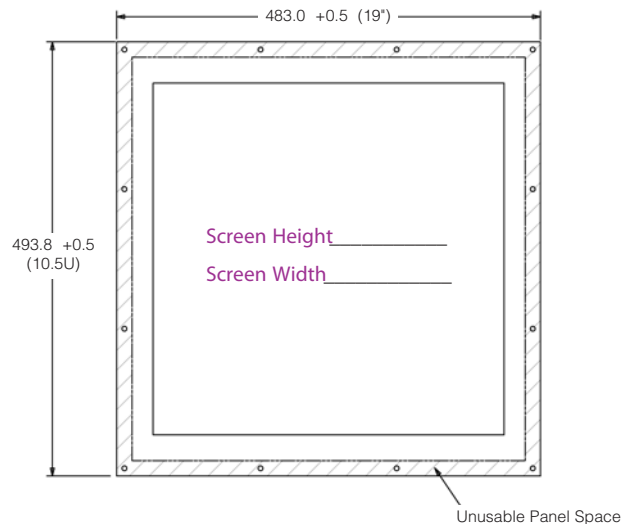

## RITTALXPRESS 2-WEEK VIP PROGRAM

Rittal Xpress offers a comprehensive selection of enclosures and fully-assembled HMI enclosures in just two weeks from receipt of your order. Use the product selection guides on the following pages to create the code for your ideal HMI enclosure. A fax order form for enclosures with two-week availability is located on the next page of this brochure.

### VIP — CODE BOX 1 — SELECT YOUR HMI ENCLOSURE SIZE

Code	Part No.	Description
A	9970870	VIP 7U H x 19" (482.5 mm) W x 7.3" 185 mm D, Including Cover Trims, Without Connection
B	9970871	VIP 7U H x 19" (482.5 mm) W x 7.3" 185 mm D, Including Cover Trims, With Top Connection
C	9970872	VIP 7U H x 19" (482.5 mm) W x 7.3" 185 mm D, Including Cover Trims, With Bottom Connection
D	9970873	VIP 7U H x 19" (482.5 mm) W x 7.3" 185 mm D, Including Cover Trims, With Top & Bottom Connection
E	9970874	VIP 10.5U H x 19" (482.5 mm) W x 7.3" 185 mm D, Including Cover Trims, Without Connection
F	9970875	VIP 10.5U H x 19" (482.5 mm) W x 7.3" 185 mm D, Including Cover Trims, With Top Connection
G	9970876	VIP 10.5U H x 19" (482.5 mm) W x 7.3" 185 mm D, Including Cover Trims, With Bottom Connection
H	9970877	VIP 10.5U H x 19" (482.5 mm) W x 7.3" 185 mm D, Including Cover Trims, With Top & Bottom Connection
I	9970878	VIP 7U H x 19" (482.5 mm) W x 7.3" 185 mm D, Including Cover Trims, Without Connection, With Keyboard Connection
J	9970879	VIP 7U H x 19" (482.5 mm) W x 7.3" 185 mm D, Including Cover Trims, With Top Connection and Keyboard Connection
K	9970880	VIP 7U H x 19" (482.5 mm) W x 7.3" 185 mm D, Including Cover Trims, With Bottom Connection and Keyboard Connection
L	9970881	VIP 7U H x 19" (482.5 mm) W x 7.3" 185 mm D, Including Cover Trims, With Top & Bottom Connection and Keyboard Connection
M	9970882	VIP 10.5U H x 19" (482.5 mm) W x 7.3" 185 mm D, Including Cover Trims, Without Connection With Keyboard Connection
N	9970883	VIP 10.5U H x 19" (482.5 mm) W x 7.3" 185 mm D, Including Cover Trims, Without Connection, With Keyboard Connection
O	9970884	VIP 10.5U H x 19" (482.5 mm) W x 7.3" 185 mm D, Including Cover Trims, With Bottom Connection
P	9970885	VIP 10.5U H x 19" (482.5 mm) W x 7.3" 185 mm D, Including Cover Trims, With Top & Bottom Connection



Without connection



Connection at top



Connection at bottom



Connection top and bottom



### VIP — CODE BOX 2 — SELECT KEYBOARD OPTIONS

Code	Part No.	Description
A	9970886	VIP Keyboard, 3.5U H x 19" (482.5 mm) W x 4.1" (105 mm) D With an Adjustable Connection and FLEX-TUBE
B	9970887	VIP Keyboard, 3.5U H x 19" (482.5 mm) W x 4.1" (105 mm) D With an Adjustable Connection
C	—	No Keyboard

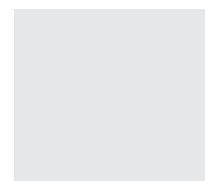
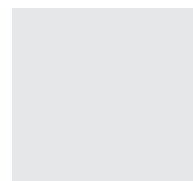



Configuring HMI enclosures has never been easier. Log onto [www.rittal.ca/rittalxpress/](http://www.rittal.ca/rittalxpress/) and complete our real-time configurator. Or fill out the simple form below and fax it to 1-800-399-0748.

Your Company \_\_\_\_\_ Your Phone \_\_\_\_\_

Your Name \_\_\_\_\_ Your Zip \_\_\_\_\_

Your E-mail \_\_\_\_\_ Your Account Number (if applicable) \_\_\_\_\_

Select your VIP enclosure size from options **A-P** on the opposite page and write the appropriate letter in the code box labeled **1**. Select your keyboard from options **A-C** on the opposite page and write the appropriate letter in the code box labeled **2**. Tell us about your cutouts.  
**A.** Write the dimensions for the screen in the space provided below.

**BUILD YOUR ENCLOSURE CODE**



V	2	1	2
---	---	---	---

**VIP — FINAL STEP — PANEL CUT OUT SIZE AND PUSHBUTTONS REQUIRED**



<p><b>7U with Pushbuttons</b>— Indicate the hole that you would like to activate by writing an <b>A</b> in each hole that will be 22.5mm and <b>B</b> in each hole that will be 30.5mm.</p>	<p><b>7U</b> – Write the dimension for the panel cutout in the space provided below</p>
<p><b>10.5U with Pushbuttons</b>— Please write the dimensions for the panel cutout in the space provided below. Please indicate the hole that you would like to activate by entering an <b>A</b> in each hole that will be 22.5mm and <b>B</b> in each hole that will be 30.5mm.</p>	<p><b>10.5U</b> – Please write the dimensions for the panel cutout in the space provided below</p>

# RITTALXPRESS 4 - WEEK OPTIPANEL PROGRAM

Rittal Xpress is the easy way to create your ideal HMI with infinite configuration opportunities and have it delivered to your doorstep in just four weeks. Log onto [www.rittal.ca/rittalxpress/HMI.cfm](http://www.rittal.ca/rittalxpress/HMI.cfm) to fill out our real-time HMI configurator or work through pages 8 and 9 of this brochure to determine the dimensions and code configuration for your ideal Optipanel enclosure.

## 4-WEEK ORDERING IS THIS EASY!

Follow the steps below. **Step 1**-fill in the dimensions of your panel in inches. **Step 2**-choose your Design Options. **Step 3**-Build your customized part number, by inserting the product code numbers in the appropriate box. **Step 4**-Upload your drawings to our website.

### STEP 1 - Panel Dimensions Required Fill in specific size in inches

\_\_\_\_\_ H x \_\_\_\_\_ W x \_\_\_\_\_ D

### STEP 2 - Design Options

#### A Installation Depth

Choose the depth you want and place its code number in the build your enclosure chart in the space labeled A.

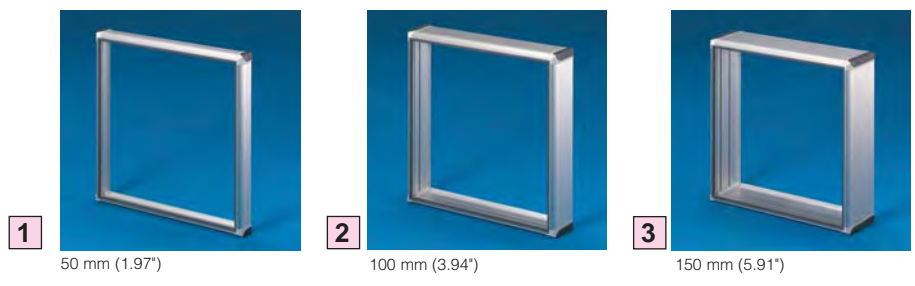

#### B Operator Housing

Choose the operator housing you want and enter its code number in the build your own enclosure chart in the space labeled B.

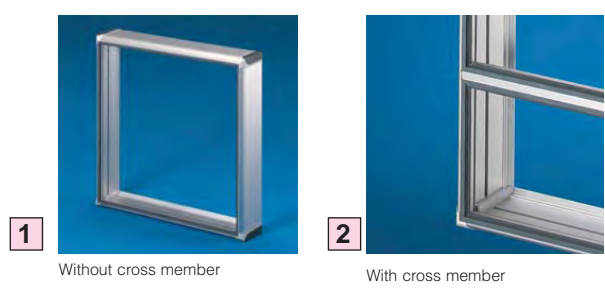

#### C Rear Wall

Choose the rear wall you want and enter its code number in the build your own enclosure chart in the space labeled C.

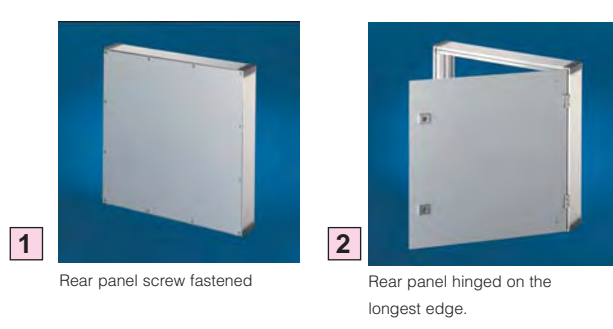



**D Support Arm Connection**

Choose the support arm connection you prefer and enter its code number in the build your own enclosure chart in the space labeled D.

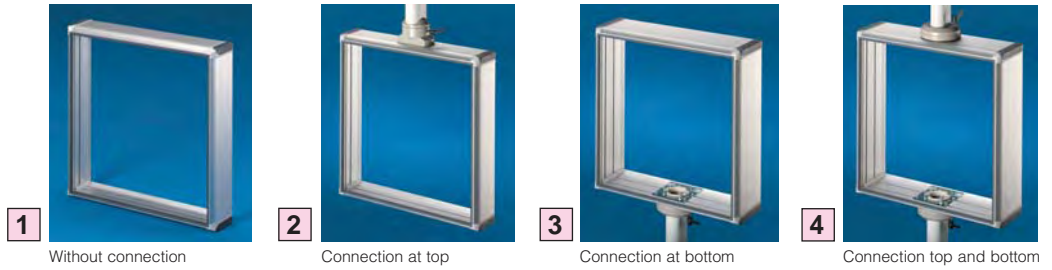

**1-4: CP-L, round**  
 Use with:  
 Enclosure Coupling: 6525.0X0  
 Enclosure Attachment: 6525.5X0  
 Angle Coupling: 6526.0X0

**5-7: CP-L, rectangular**  
 Use with:  
 Enclosure Coupling: 6525.1X0  
 Enclosure Attachment: 6525.6X0



**E Keyboard Housing**

Choose the keyboard housing connection you prefer and enter its code number in the build your own enclosure chart in the space labeled E.



**Step 3**, simply take the corresponding product code number by each of your selections in **Step 2** and place the numbers in the chart below. **Step 5**, fax the product code that you created by your selections in steps 2-4 along with your drawings to **1-800-477-4003**. Download our drawings from [www.rittal-corp.com/rittalxpress/hmi](http://www.rittal-corp.com/rittalxpress/hmi) and complete the drawings with your requirements. Submit the completed drawings along with your RFQ either online at [www.rittal-corp.com/rittalxpress/hmi](http://www.rittal-corp.com/rittalxpress/hmi) or fax to **1-800-477-4003**. Rittal will send a quote for your enclosure.

Step 3 - BUILD YOUR ENCLOSURE CODE

<b>04</b>	Height _____ x Width _____ x Depth _____ Panel Dimension in inches	A	B	C	D	E
-----------	---	---	---	---	---	---

STEP 4 - CutOutSpecs

Download our drawings from [www.rittal-corp.com/rittalxpress/hmi](http://www.rittal-corp.com/rittalxpress/hmi) and complete the drawings with your requirements. Submit the completed drawings along with your RFQ either online at [www.rittal.carittalxpress/hmi.cfm](http://www.rittal.carittalxpress/hmi.cfm) or fax to **1-800-399-0748**.

## RITTALXPRESS 4-WEEK VIP PROGRAM

Rittal Xpress is the easy way to create your ideal HMI with infinite configuration opportunities and have it delivered to your doorstep in just four weeks. Log onto [www.rittal.ca/rittalxpress/HMI.cfm](http://www.rittal.ca/rittalxpress/HMI.cfm) to fill out our real-time HMI configurator or work through pages 10 – 13 of this brochure.

### 4-WEEK ORDERING IS THIS EASY!

Follow the steps below. **Step 1**-fill in the dimensions of your panel in inches. **Step 2**-choose your basic features. **Step 3**-select your Operator Housing. **Step 4**-select your Keyboard Housing. **Step 5**-fill in your build your enclosure code. **Step 6**-Upload your drawings to our website: [www.rittal.ca/rittalxpress/HMI.cfm](http://www.rittal.ca/rittalxpress/HMI.cfm)

### STEP 1 - Panel Dimensions Required Fill in specific size in inches

\_\_\_\_\_ H x \_\_\_\_\_ W x \_\_\_\_\_ D

### STEP 2 - Basic Features

**A Frame Style**  
Choose the frame style you want and place its code number in the build your enclosure chart in the space labeled A.



### STEP 3 - Operator Housing

**B Installation Depth**  
Choose the depth you want and place its code number in the build your enclosure chart in the space labeled B.

**Material:**  
Enclosure: Extruded aluminum section  
Corner protectors: Plastic, self-extinguishing  
**Finish:**  
Enclosure: Natural anodized

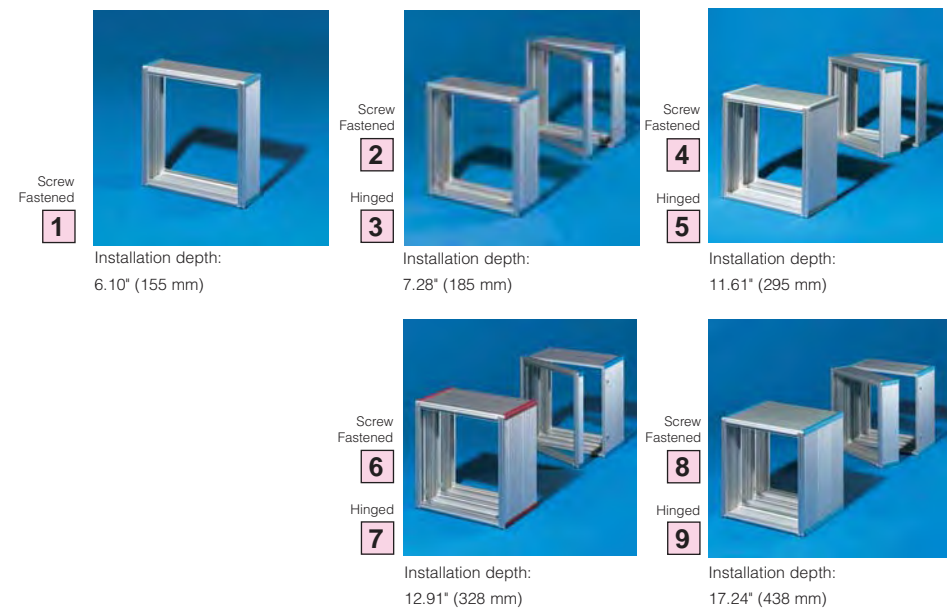

## STEP 3 - Operator Housing

### C Front Design

Choose the front design you prefer and enter its code number in the build your own enclosure chart in the space labeled C.

#### Cross member

For horizontal and/or vertical division.

#### Material:

Extruded aluminum section, RAL 7035.

#### Sealing bar

For horizontal and/or vertical division. The "slot-free" division produces a height gain of 1.10" (28 mm).

#### Material:

Extruded aluminum section 8 x 0.79" (20 mm), natural anodized

#### Adaptor plate

Material thickness:  
0.12" (3 mm) aluminum, natural anodized.

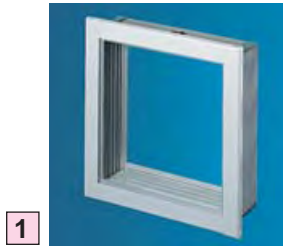

1 Without cross member



2 With one cross member



3 With two cross members



4 With hinged front panel

### D Cooling Fins

Choose the cooling fins you prefer and enter its code number in the build your own enclosure chart in the space labeled D.

Enclosures with an installation depth of 185 mm (7.28") and 328 mm (12.91") do not have any fins immediately behind the front frame at a depth of 44 mm (1.73"). The color of the corner protectors matches the trim color selected under **section F**.



1 No fins

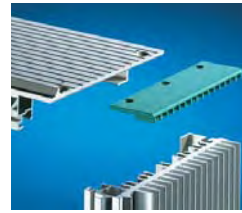

2 Fins at sides

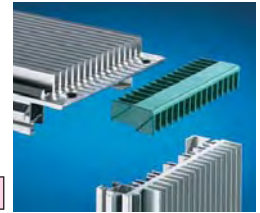

3 Continuous fins

### E Trim Types

Choose the trim types you prefer and enter its code number in the build your own enclosure chart in the space labeled E.



1 Cover trim  
To conceal the front panel assembly screws. For front panel thickness up to 3.5 mm (0.14").



2 End trim  
Attractively finishes off the space between the front panel and the frame section. For all front panel thicknesses.



3 Spacer trim  
For installed equipment flush with the frame section. For front panel thickness up to approx. 3.5 mm (0.14").

### F Trim Colors

Choose the trim color you prefer and enter its code number in the build your own enclosure chart in the space labeled F.

**Note:** Enclosure corner protectors are also supplied in the chosen color.



1 **Turquoise**  
(similar to RAL 5018)



2 **Bright blue**  
(similar to RAL 5005)



3 **Bright red**  
(similar to RAL 3001)



5 **Pebble grey**  
(similar to RAL 7030)

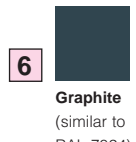

6 **Graphite**  
(similar to RAL 7024)

**G Support Arm Connection** – Choose the support arm connection you prefer and enter its code number in the build your own enclosure chart in the space labeled G.

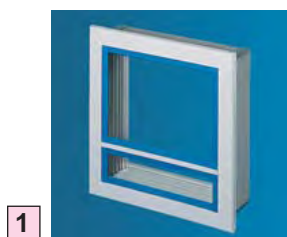

1 Without connection

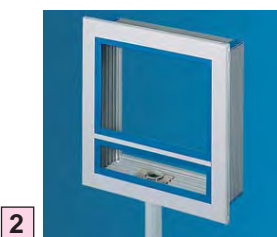

2 Connection, bottom

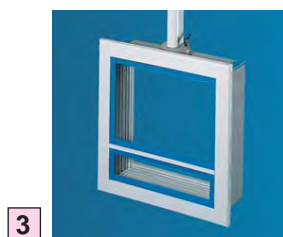

3 Connection, top

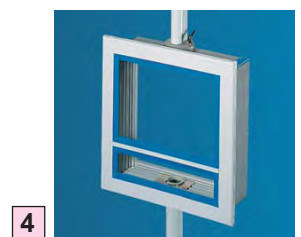

4 Connection, top and bottom, one cover plate included

## H Mounting for Keyboard Housing

Choose the keyboard mounting you prefer and enter its code number in the build your own enclosure chart in the space labeled H.

1

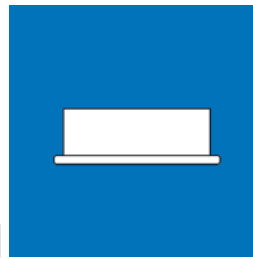

Without connection to the keyboard housing

2

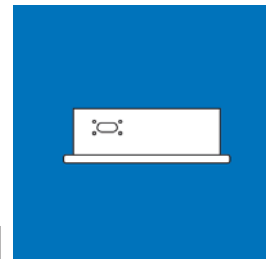

Connection to frame connector either fixed or adjustable

## I Rear Panel

Choose the rear panel you prefer and enter its code number in the build your own enclosure chart in the space labeled I.

1



Screw fastened  
**Material:**  
Aluminum, natural anodized.

2



Hinged  
For rapid service access  
**Material:**  
Aluminum, natural anodized.

## J Keyboard Depth

Choose the keyboard depth you prefer and enter its code number in the build your own enclosure chart in the space labeled J.

Without fins.  
For installing or positioning keyboards on top (with a depth of 1.06" (27 mm).  
All keyboard housings are custom-produced to your dimensions. When selecting the wide front frame, the width of the keyboard housing depends on the operating housing.

**Material:**  
Extruded aluminum section

1



Installation depth 1.73" (44 mm) for built-in keyboards

2



Installation depth 4.13" (105 mm) for built-in keyboards

## K Trim Types

Choose the trim type you prefer and enter its code number in the build your own enclosure chart in the space labeled K.

Cannot be selected with keyboard housing depth 1.06" (27 mm) or support for keyboards.

1



Cover trim  
To conceal the front panel assembly screws. For front panel thickness up to 0.14" (3.5 mm).

2



End trim  
Attractively finishes off the space between the front panel and the frame section. For all front panel thicknesses.

3



Spacer trim  
For installed equipment flush with the frame section. For front panel thickness up to approx. 0.14" (3.5 mm).

## STEP 4 - Keyboard Housing

### L Trim Colors

Choose the trim color you prefer and enter its code number in the build your own enclosure chart in the space labeled L.

**Note:** Enclosure corner protectors are also supplied in the chosen color.

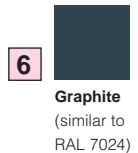

### M Keyboard Connector

Choose the keyboard connector you prefer and enter its code number in the build your own enclosure chart in the space labeled M.

Supplied loose with the keyboard housing for connecting operating housings and keyboard housings.

**Material:**  
 Die-cast zinc, RAL 7035



Frame connector, (fixed)



Frame connector,  
 (adjustable)

### N Cable Tube

Choose the cable tube you prefer and enter its code number in the build your own enclosure chart in the space labeled N.

Supplied loose with the keyboard housing for connecting operating housings and keyboard housings.

**Material:**  
 Die-cast zinc, RAL 7035



Without cable tube



Cable tube, rigid



Cable tube, flexible

**Step 5**, simply take the corresponding product code number by each of your selections in **Steps 3 & 4** and place the numbers in the chart below. **Step 6:** Log onto [www.rittal.ca/rittalxpress/hmi.cfm](http://www.rittal.ca/rittalxpress/hmi.cfm) to download our drawings. Make your changes to our drawings and submit the complete drawings along with your RFQ either online at [www.rittal.ca/rittalxpress/hmi.cfm](http://www.rittal.ca/rittalxpress/hmi.cfm) or fax to **1-800-399-0748** Rittal will send a quote for your enclosure. Rittal will send a quote for your enclosure.

## Step 5 - BUILD YOUR ENCLOSURE CODE



Height                      x Width                      x Depth  
 Panel Dimension in inches

## STEP 6 - CutOutSpecs

Log onto [www.rittal.ca/rittalxpress/hmi.cfm](http://www.rittal.ca/rittalxpress/hmi.cfm) to download our drawings. Make your changes to our drawings and submit the complete drawings along with your RFQ either online at [www.rittal.ca/rittalxpress/hmi.cfm](http://www.rittal.ca/rittalxpress/hmi.cfm) or fax to **1-800-399-0748**. Rittal will send a quote for your enclosure.

# Rittal HMI Solutions



**Industrial Enclosures**



**Wallmount Enclosures**



**System Climate Control**



**Power Distribution**



**IT Solutions**



**HMI Enclosures**

**Rittal Systems Ltd.** • 7320 Pacific Circle • Mississauga, Ontario • L5T 1V1 • Canada  
Phone: (905) 795-0777 • Fax: (905) 795-9548 • Toll-free: 1-800-399-0748  
www.rittal.ca • Email: rittal.systems@rittal.ca

**Rittal Corporation** • One Rittal Place • Springfield, OH • 45504 • USA  
Phone: (937) 399-0500 • Fax: (937) 390-5599 • Toll-free: 1-800-477-4000  
www.rittal-corp.com • Email: rittal@rittal-corp.com



*Switch to perfection* **RITTAL**